



Model VCV13



### SPECIFICATIONS:

Double deck cook and hold oven, Vulcan-Hart Model No. VCV13. Heavy duty 20 gauge polished stainless steel cabinet with welded tubular steel inner frame for increased durability. Stainless steel door with heavy duty hinges, door latch mechanism, and long lasting silicone gaskets. Fully insulated, 2" in top and 1" in sides and bottom. Interior pan supports removable for easy cleaning. Four wire cooking racks. Accepts eight 18" x 26" x 1" baking pans per section. Self contained power head easily removable. Includes metal sheathed heating elements, convection fan, electronic controls and "power on", "cooking" and "holding" cycle indicator lights. Low speed fan provides even heat distribution and natural browning of meat products. Cook temperature adjusts to 250°F. Holding temperature adjusts to 200°F. Dual voltage, 208/240 volt, 60 Hz, single phase power supply. Furnished with 6' power cord and NEMA 6-30 plug.

Exterior dimensions: 22¼"w x 30¾"d x 78"h on 5" heavy duty casters (2 swivel with brakes, 2 rigid).

UL listed. UL listed to Canadian safety standards. Classified by UL to NSF Std. #4.

### STANDARD FEATURES

- Double deck cook and hold oven accepts eight 18" x 26" x 1" baking pans per oven section.
- Heavy duty 20 gauge polished stainless steel cabinet with welded tubular steel inner frame for increased durability.
- Stainless steel door with heavy duty hinges, door latch mechanism, and long lasting silicone gaskets.
- Fully insulated: 2" in top and 1" in sides, bottom and door.
- Interior pan supports removable for easy cleaning.
- Two wire cooking racks per oven section.
- Self-contained power head easily removable. Includes metal sheathed heating elements, convection fan, electronic controls and "power on", "cooking" and "holding" cycle indicator lights. Cook temperatures adjusts to 250°F. Holding temperature adjusts to 200°F.
- Set of four 5" casters, 2 swivel with brakes, 2 rigid.
- Dual voltage 208/240 volt, 60 Hz, 1 phase power supply. Furnished with 6' power cord and NEMA 6-30 plug.
- One year limited parts and labor warranty.

### OPTIONS

- Perimeter bumper system.
- 120 volt smoker attachment.
- Two year extended limited parts and labor warranty.

### ACCESSORIES

- Extra set of universal pan supports.
- Extra wire cooking rack.



# MODEL VCV13

COOK AND HOLD OVEN

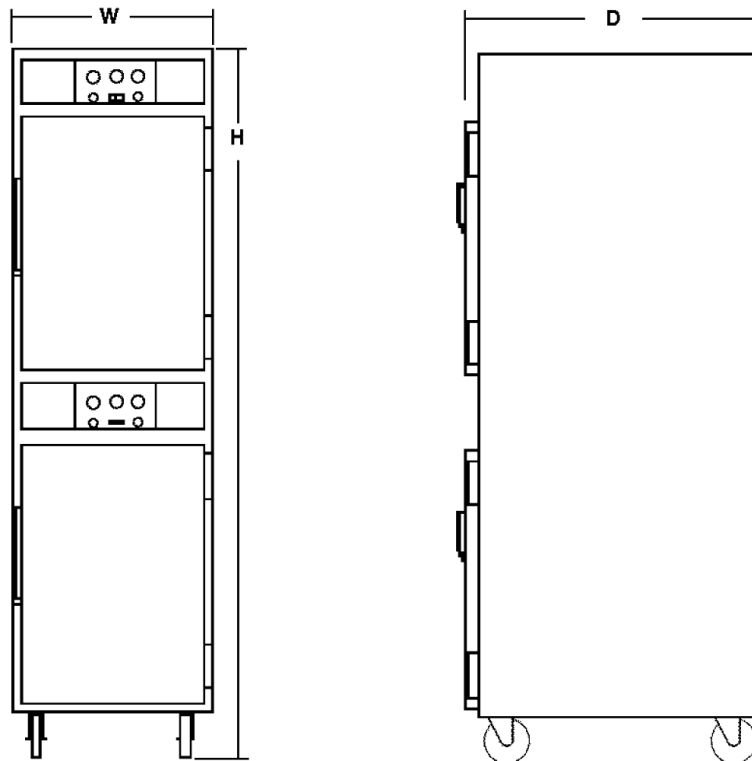
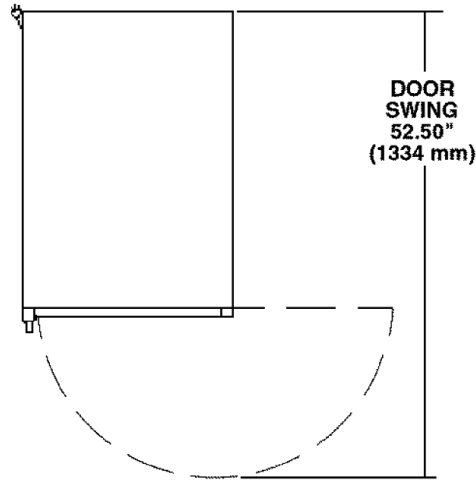

Model No.	Pan* Capacity	Meat* Capacity	High	Deep	Wide	Shipping Weight	Volts	Watts	Amps
VCV13	8 each 18" x 26" pans	120# 54.5 kg	78" 1981 mm	30 <sup>3</sup> / <sub>4</sub> " 781 mm	22 <sup>1</sup> / <sub>4</sub> " 566 mm	438# 199 kg	208 240	3800 5060	19 22

\*per compartment

**NOTE:** In line with its policy to continually improve its products, Vulcan-Hart Company reserves the right to change materials and specifications without notice.

**VULCAN-HART COMPANY, P.O. BOX 696, LOUISVILLE, KY 40201, TEL. 1-800-814-2028**  
**502-778-2791 QUOTE & ORDER FAX: 1-800-444-0602**